

8 7 6 5 4 3 2 1

REVISIONS			
REV.	DESCRIPTION	DATE	APPROVED

D

C

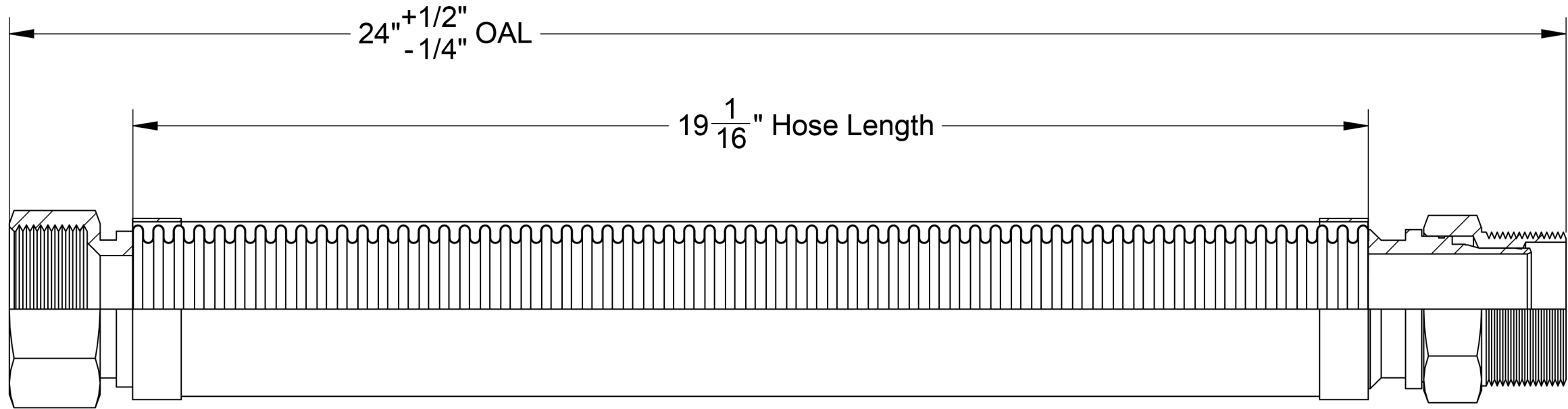

D

C

B

A

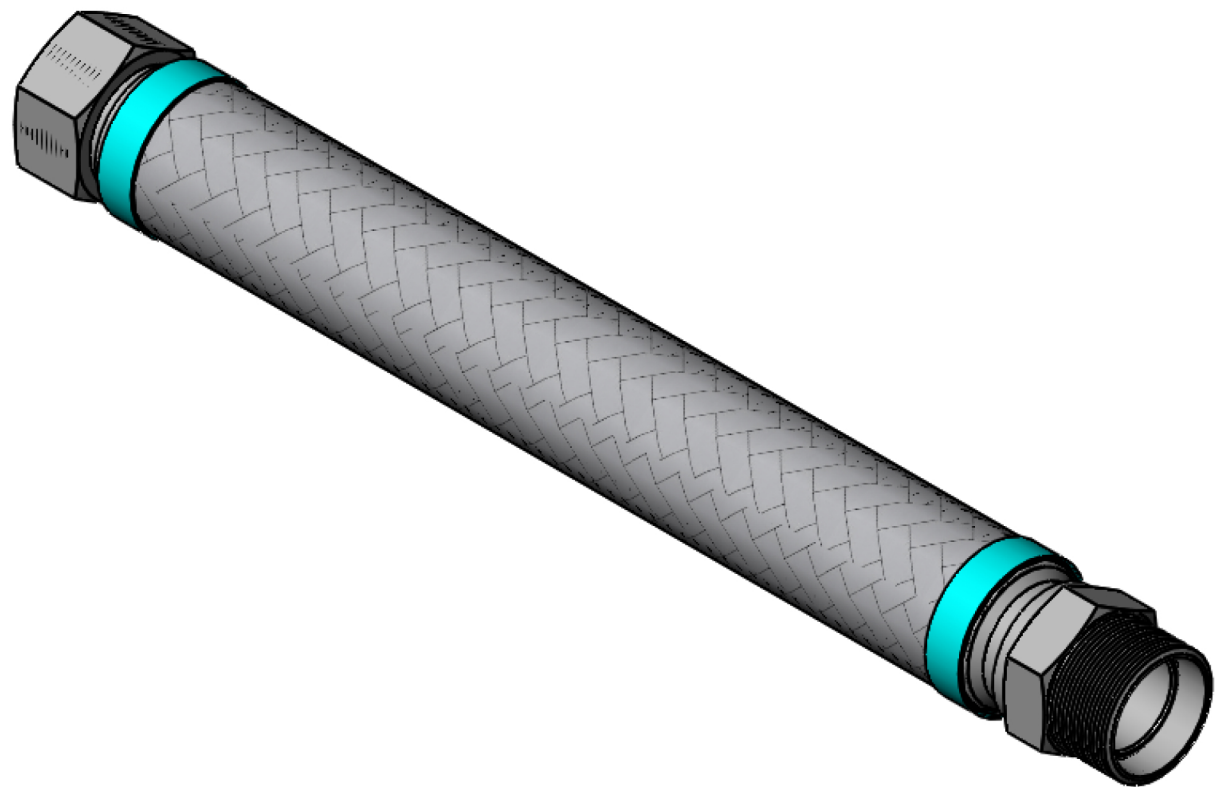

8 7 6 5 4 3 2 1

ITEM #	QTY.	PART NUMBER	DESCRIPTION	MATERIAL	WEIGHT
1	1	HOSE	300 Series Stainless HYDROFORMED Corrugated Hose	Stainless Steel	1.09
2	1	BRAID	300 Series Stainless Steel	Stainless Steel	0.09
3	2	BRAID COLLAR	0.05" Thick	Stainless Steel	0.09
4	1	2" FEMALE	2" Female, 2"x11-1/2" Thread, 2.38" Hex	Carbon Steel	0.83
5	1	2" MALE SWIVEL	2" Male Swivel, 2"x11-1/2" Thread, 2.38" Hex	Carbon Steel	0.93

	<b>HOSE MASTER Inc.</b> 1233 East 222nd Street • Cleveland, Ohio 44117 (800) 221-2319 • Fax: (216) 481-7557 • www.hosemaster.com Locations: <b>Cleveland • Houston</b>		Registered to: ISO 9001 : 2000

Projection:	Customer: Hose Master Inc.	Prepared By: <b>kannk</b>
	Reference: Fire-Shield - 2" Female x 2" Male Swivel x 24" OAL	CALC. WEIGHT: <b>3 lbs.</b> Date: <b>9/24/2009</b>

Description: **2" ID x 24" OAL 300 Series Stainless HYDROFORMED Corrugated Hose covered by 300 Series Stainless Braid. UL Approved 2" Female Connector x 2" Male Swivel Connector**

Drawing #:	<b>FSFS0200x24</b>	Rev.:	<b>-</b>	SHEET	<b>1 OF 1</b>
------------	--------------------	-------	----------	-------	---------------